



Sustained Release Intra-articular Medication



Sustained release intra-articular medication could last three to four months, or longer

Photo by: Ian Woodley

Imagine a single injection of a long-acting, inexpensive drug to relieve joint inflammation with no adverse side effects on other organs such as the gut and kidney. That is what Ontario Veterinary College researcher, Mark Hurtig and his team envision as they embark on new technology that could revolutionize joint injections and much more. Sustained release formulations

could have great potential in delivering antibiotics, parasiticides or other drugs that require long treatment regimes or treatment of tissues that are difficult to penetrate with oral or other injectable drugs. There could be applications for direct injection of drugs into joints, the spinal column, tendon sheaths and even eyes.

Hurtig's current research project on sustained release using intra-articular medication began in the Spring of 2016 with objectives of slowing down the progression and signs of joint disease. Currently there are no drugs registered for use in the treatment of equine osteoarthritis, partly because there are challenges with conventional drugs reaching joint tissues in adequate concentrations. A good example is glucosamine which has minimal absorption by the equine gastrointestinal tract.

Describing the intra-articular medication in development, Hurtig says, "We can treat a single or multiple joints without having to poison the whole horse."

continued on page 2...

The science of equine health and welfare is moving so fast that it is no longer true to say, "All I need to know about horses I can learn in the stable." For the horse caregiver, this poses the problem of staying up to date, and this newsletter is one of many initiatives at Equine Guelph designed to help.

This issue features research funded by the horse industry in Ontario that will impact on the health of your horses' joints, arteries and blood, and intestinal system, and on the mental health of people benefiting from equine therapy.

We also bring you two new methods for staying up to date: The Horse Portal and the training opportunities it opens up for you, and an online tool for managing extremes of temperature.

*Dr. Jeff Thomason and
Dr. John Baird,
Co-Chairs, Equine Guelph Research
Committee*

New ThermoRegulator Healthcare Tool

Equine Guelph has partnered with internationally renowned blanket manufacturer, Bucas of Ireland and is pleased to announce the launch of the ‘ThermoRegulator Healthcare Tool’.

The new interactive online tool explores thermoregulation in all seasons to help horse owners avoid over-heating and dehydration along with a variety of

sicknesses caused as a result of chilling and other preventable health concerns.

Bucas managing director, Ulf Casselbrant says, “Bucas is pleased to partner with Equine Guelph in the development of the ‘ThermoRegulator Healthcare Tool’, as it is an excellent resource for the horse owner in understanding the principles of thermoregulation in horses and helpful in

the proper use of blanket protection for their horse.”

To learn more about thermoregulation and to decide if your horse is a candidate to be covered by a blanket – go to the ThermoRegulator Healthcare Tool at EquineGuelph.ca.



“I’M NOT COLD, MY OWNER, SHE’S COLD!”

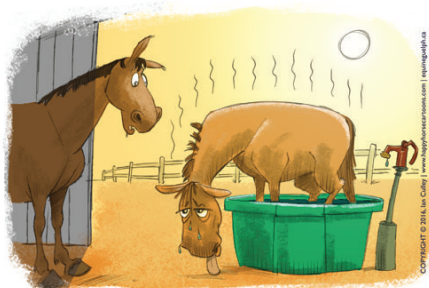

“I WAS GOING TO DRINK THAT. ... UH, NEVER MIND.”



Sustained release intra-articular medication continued from page 1

How does it work?

“Sustained release technology targets the joint space and the joint space alone,” says Hurtig. “The drug levels in the rest of the body are miniscule.” With low systemic exposure, this means there should be no problems with ulcers, renal disease and other complications that can result from NSAIDS. Sustained release technology is about binding the drug to a carrier and having that carrier break down slowly to release the active pharmacological ingredient (API). In this case a liquid polymer mixture becomes a semi-solid gel after it is injected into the joint. The gel is broken down slowly releasing the API which can be a drug, therapeutic protein or growth factor. The polymer mixture is described by Hurtig as ‘comprised of garden variety molecules’ which are readily available, inexpensive and well accepted as safe in food and drug manufacturing.

environment, this means less impact on soil and drinking water.” Less drugs could prove better for the horse, environment and pocketbook.



Photo by: Erin Cummins

Less drugs could prove better for the horse, environment and pocketbook.

nutraceuticals help control the symptoms. These treatments can suppress inflammation but have no proven effect on repairing cartilage. In some cases, such as prolonged use of long acting corticosteroids, there is a negative metabolic effect on articular cartilage and can promote additional joint degeneration. Hyaluronic acid, platelet rich plasma, and many of the new biologic therapies have a relatively short acting effect of weeks to a few months. Prolonging the effect of such treatments with sustained release carriers could be one answer to practical cost effective management of joint disease. Drugs that are too expensive or toxic to administer to horses by other routes could be delivered by direct injection.

A little does a lot

Dr. Hurtig’s team has shown that as little as 200mg of drug (a small fraction of one oral dose) could last three to four months or longer. In many cases this means using two to three orders of magnitude less drug. “It is a really local therapy and a very green technology,” explains Hurtig. “With less drugs being excreted out into the

Traditional treatment of osteoarthritis

Conventional treatments manage the pain and inflammation in joint disease. There are no treatments registered for treating equine osteoarthritis though injectable corticosteroids, hyaluronic acid, platelet rich plasma, IRAP (interleukin receptor antagonist protein), NSAIDs and

What’s next?

Hurtig’s research collaborations in sustained release intra-articular medication could revolutionize the treatment of osteoarthritis. In collaboration with Dr. Beth Gillies at the University of Western Ontario, they have been developing carrier/drug prototypes for preliminary trials in horses.

Funding for this research has been provided by Equine Guelph.

By: Jackie Bellamy-Zions

TheHorsePortal.ca – Join the Herd!

Equine Guelph announces the official launch of TheHorsePortal.ca – a new portal for industry training in an easily-accessible online format for the equine industry. From the Rockies to the eastern islands, the portal will bring together horse people like never before to stay current on best health and welfare practices. The new program, resulting from an innovative industry partnership, provides horse people with short, practical online training to stay up-to-date with the latest information on equine care.

The inaugural short courses:

**'Equine Welfare – Canada's Code'
March 6 - 24**

**'Equine Biosecurity – Canada's
Standard' April 10 - 28**

For any person responsible for a horse, it is essential to learn the national standards. These first two short courses on The Horse Portal are important offerings for caregivers and horses alike. Each day, new scientific knowledge emerges on how to better care for horses and deal with emerging issues. It is everyone's responsibility to stay current on best health and welfare practices and industry standards.

“Through The Horse Portal, horse caregivers can access common sense,

practical training that can be used on a daily basis,” says Gayle Ecker, director of Equine Guelph. “Equine Guelph is pleased to partner with the equine industry across the nation bringing Canadians together to learn about equine welfare and care as a community.”

Equine Guelph has partnered with ten English-speaking provincial equestrian federations across Canada to offer their members equine training and education through The Horse Portal. The portal is also available to non-federation members. From racing to performance to the backyard pony, this portal was developed to educate and benefit all segments of the equine industry.

This project is funded in part through *Growing Forward 2* (GF2), a federal-provincial-territorial initiative. The Agricultural Adaptation Council assists in the delivery of GF2 in Ontario. Other partners include: Campbell Centre for the Study of Animal Welfare, Equestrian Canada, Farm & Food Care Ontario, Greenhawk, Omega Alpha Equine, Ontario Equestrian Federation, Ontario Society for the Prevention of Cruelty to Animals and Standardbred Canada. Participating Federations include: Alberta Equestrian Federation, Equine Association of Yukon, Horse Council British Columbia, Island

Horse Council, Manitoba Horse Council, New Brunswick Equestrian Association, Newfoundland and Labrador Equestrian Association, Nova Scotia Equestrian Federation, Ontario Equestrian Federation and Saskatchewan Horse Federation. National training partner is Equestrian Canada.

**For more information, go to
TheHorsePortal.ca**

By: Henrietta Coole

When you support
EQUINE GUELPH
you make a difference
in horse health
and well-being.



We can't do it without you.

Please make a gift online at
www.equineguelph.ca
or call 1-888-266-3108.

Charitable Registration Number
10816 1829 RR 0001

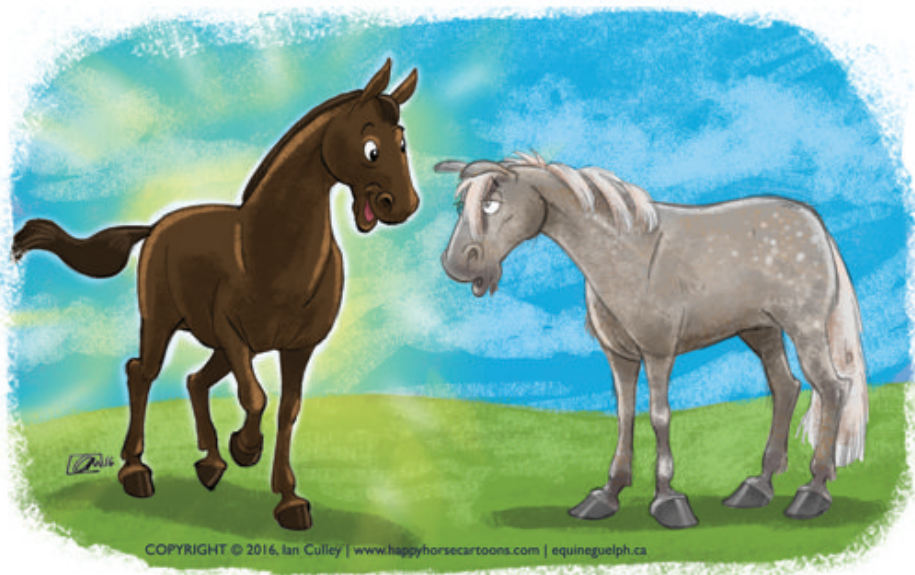

COPYRIGHT © 2016, Ian Culley | www.happyhorsecartoons.com | equineguelph.ca

"HEY, MY OWNER TOOK THE CODE OF PRACTICE COURSE, DID YOURS?"

Model Research Leads to Advanced Studies

A New Wave in Research on Equine Arterial Calcification

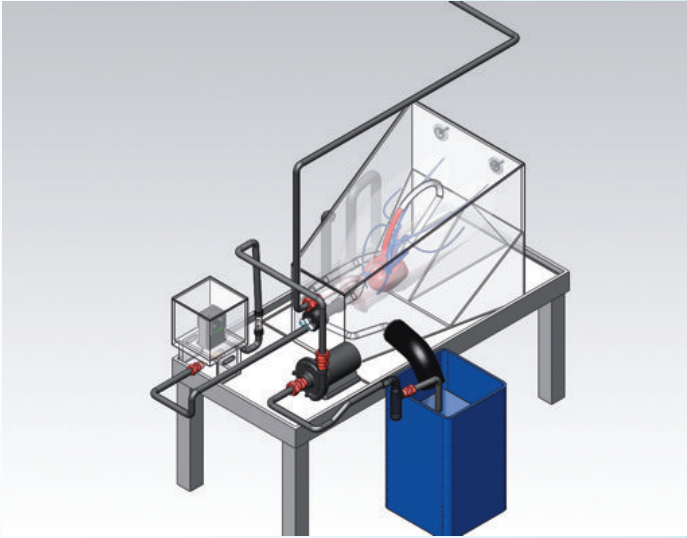

It was only two years ago when OVC researcher, Dr. Luis Arroyo and his team began studying equine arterial calcification using the ex-vivo model illustrated here. With calcification, the artery walls fill with fibrous collagen, causing the loss of elasticity that normally enables this large blood vessel to pump blood from the heart to the lungs. Thanks to Arroyo and his team, the research is moving forward toward understanding what is normal and what is not. They have perfected a technique for catheter placement in the lungs using the model and ultrasound equipment guiding the first catheter sleeve. Now they are able to measure pulse wave velocity (PWV) of blood traveling through the arteries in live horses with a uniquely developed system. One catheter gives access to the veins, another to the lungs, and a third one to record the measurements.

Bioengineering graduate student Bruce Guest continues ex-vivo studies. He has used the model to develop the placement of the special catheters, outfitted with two pressure sensors, in the lungs. The University of Guelph is a pioneer in this equine technology that measures the wave of blood travelling between two sensors per heart beat (PWV) following a classic distance/time equation. All the tests now being conducted in live studies have been first tested in the model using intravascular endoscopy to guide the 17 cm advanced catheter into position.

Using new technology, Arroyo and his team set out to determine if they could measure pulse wave velocity and establish numbers in 12 horses. What they discovered post-mortem, in this preliminary study, is that the horses with lesions (indicating the presence of arterial calcification) had a higher PWV. The diseased horses had PWV of three and a half metres per second versus two metres per second in a healthy horse.

In human studies pulmonary arterial stiffness is emerging as an important component of pulmonary hypertension but the relationship between conditions like exercise-induced pulmonary hemorrhage (EIPH) and stiffening of the arteries does not appear to have been explored. It is hypothesized that equine arterial calcification is related to high intensity exercise whereas in humans the culprits are lack of exercise and diet. It is too soon to know, from this small study, if measuring pulse wave velocity will be the wave of the future in diagnostics for equine arterial calcification but extensive human studies in PWV have revealed correlation. Arroyo references a human study which indicated people with pulmonary hypertension averaged a PWV of 7.5 metres per second versus a healthy individual where it was 3.5 metres per second.

In human medicine there are methods to detect calcified arteries using ultrasound, MRI, CT scans and other techniques but this is not possible in horses. A horse's arteries are far too big to have success scanning with intravascular ultrasound. Not having a viable way to diagnose calcified arteries in horses drives the need for further research. In the next steps studying PWV, Arroyo and his team, Dr. John Runciman, Dr. Gonzalo Silva, and Bruce Guest, set out to determine if there are differences in bleeders versus non-bleeders. They will first need to gather a research herd of horses affected by exercise-induced pulmonary hemorrhage (EIPH) before moving on to compare PWV to that of healthy horses under exercise conditions.

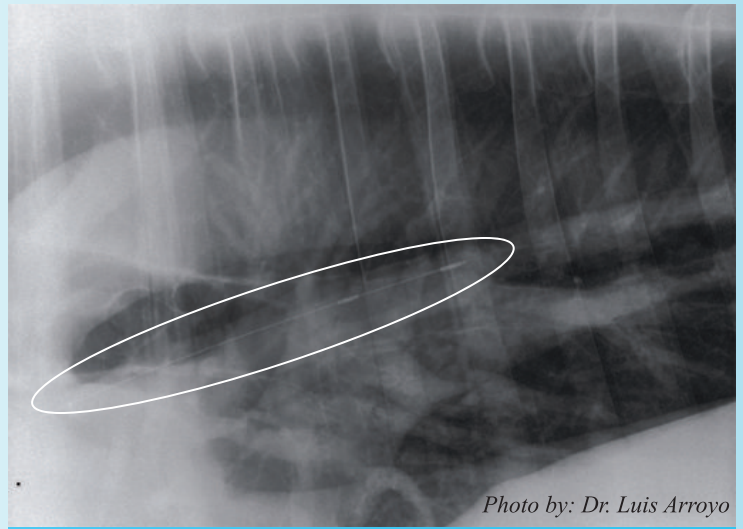

Photo by: Dr. Luis Arroyo

Specialized catheter measuring PWV

of Cardiovascular and Gut Health

Getting to Know the Gut

Gastrointestinal (GI) health has garnered increasing focus not only in human research but also in the equid. Intense research has been ongoing to better understand the ecosystem of this hind gut fermenter. Dr. Luis Arroyo and his team are once again proving themselves to be model researchers; this time creating a “glass gut” model. By simulating cecum and colon conditions using this in-vitro model, they plan to study microbiota and its crucial role in health.

Once they establish what is “normal” in a healthy horses’ GI, long term research could lead to an understanding of what disruptions to the microbiota lead to disorders such as colitis, laminitis and colic. “A better understanding of the microbial ecosystem under healthy conditions will be imperative before research can proceed into how disturbances in microbiota homeostasis impact its function,” says Arroyo.

The in-vitro model uses continuous culture (chemostat) systems, mimicking the nutritional and environmental conditions of the horses’ hind gut to achieve cultures of whole gut microbial communities. Seeded with GI samples obtained from horses, the researchers then analyze the microbial population compositions. “The first thing we want to know is how the gut flora of the horses normally behave in order to be able to build a well-established in-vitro model of the gut,” says Arroyo.

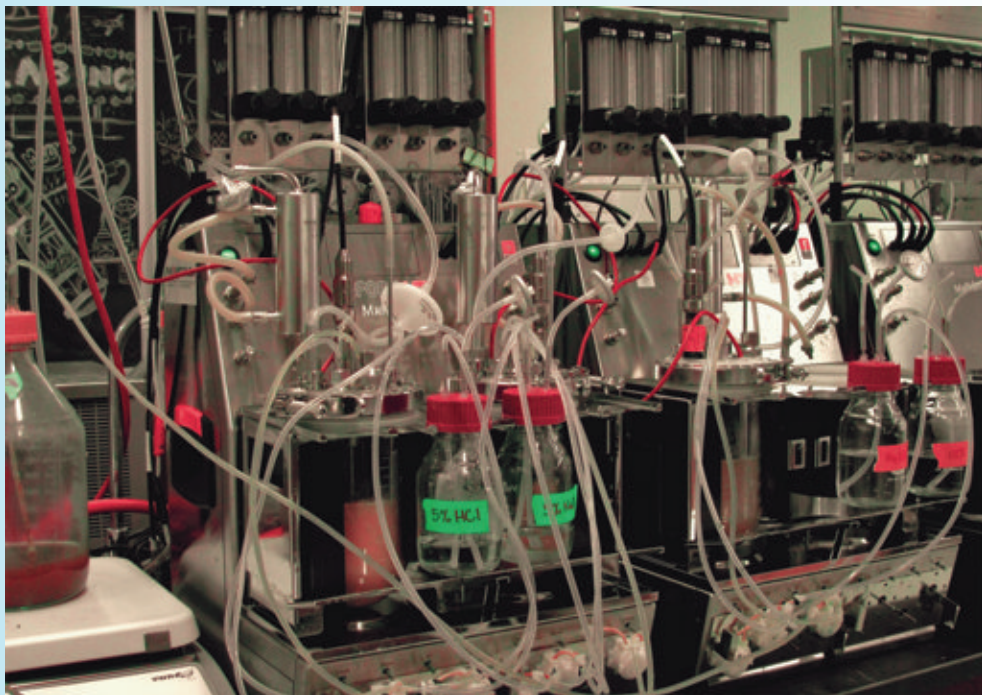

Dr. Emma Allen-Verco Robogut system.

Photo by: Dr. Luis Arroyo

Samples have been collected from various parts of the intestinal tract of healthy horses to study and compare the genomics of their microbiomes. For example: comparing flora in the small intestine to that of the cecum. They have extracted DNA from these samples and are moving into gene sequencing. The research will also compare gut contents from horses that have had colitis to a healthy control.

Arroyo with co-investigator and mentor Dr. Emma Allen-Verco, from the Department of Molecular and Cellular Biology at the University of Guelph will then extract fluid from the intestinal contents to see what metabolites have been produced in horses with and without colitis. This will provide important information for a well-established in-vitro model of a healthy gut. Dr Allen-Vercoe recently developed an in-vitro human gut microbiota mixture of 33 isolates for the successful resolution of *C. difficile*-associated diarrhea in human patients. The team will also be aided by Bruna Santos, a graduate student from Brazil, from the Emerging Leaders of Latin America program supported by the Canadian government.

Although this project is designed to “get to know” what is normal and what is normally happening in the gut, long term benefits to the horse industry may result from prevention of flora disruption strategies, and/or the development of products to counteract the damage to the resident gut flora.

Research funding for these projects have been provided by Equine Guelph.

By: Jackie Bellamy-Zions

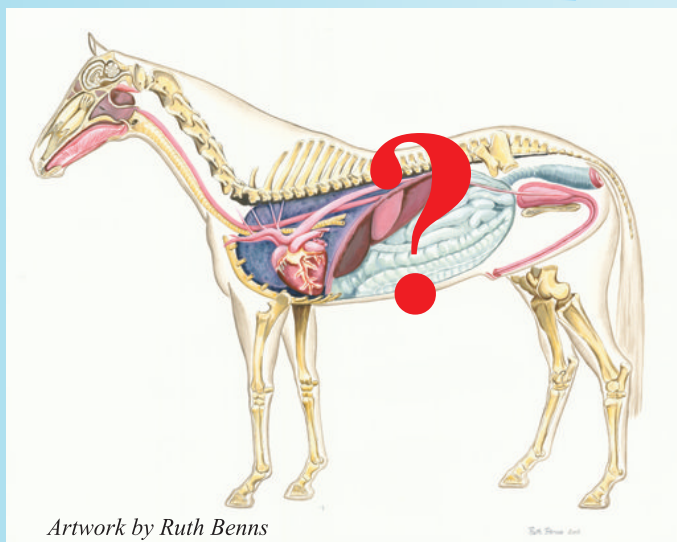

Artwork by Ruth Benns

© Dr. Steve Dale

How Therapy Horses React to Humans

In 2016, Prof. Katrina Merkies, Animal Biosciences at the University of Guelph set out to learn if horses responded differently to people with post-traumatic stress disorder (PTSD). The study took place at Sunrise Therapeutic Riding and Learning Centre in Puslinch, ON using seventeen of their tried and true therapy horses who had been in the program for two years or more.

“The most difficult part of the study was recruiting volunteers for the control group,” says Merkies who closely matched the PTSD applicants with their doppelgangers in gender, height, build and as many other characteristics as possible. Professional acting coach, Tony Babcock of Toronto was on hand to make sure the control group reflected the same physical movements and mannerisms as the PTSD subject who entered the enclosure before them. Video footage was taken to compare the horses’ reactions in both scenarios. Heart rates were also monitored, salivary cortisol concentrations measured and close attention was paid to the horses’ body language including head height, ear orientation, gait and distance from human.

Findings did not reveal different responses from the horses in the presence of the PTSD subjects or the control group. This suggests that the horses were not responding to emotional emanations. There were differing reactions between the pairs (PTSD and control subject) inferring that horses were reacting to the physical. Merkies hypothesizes, “This could be reassuring to the PTSD recipients of equine therapy; that the horses react to them as an individual and not to their mental illness.”

Differences were noted from the baseline, when the horse was alone in the enclosure, to when there was a human present. The horses would vocalize more and chew more before the human was introduced. Horses would also display higher head carriage before the person entered the arena. With human presence, the horses all moved slower and then faster after the person left the ring. In all cases the horse displayed more relaxed posture and movement during human presence than in the baseline and after the person left the enclosure. Cortisol levels were not affected throughout the study in the saliva samples taken.

One interesting and unexpected result was the difference in horse heart rate; not between the control group and PTSD subject but between persons with and without horse experience. The more experienced horse person elicited a higher heart rate in the equine than a human with little to no previous exposure to horses. Merkies has noted this reaction in previous studies involving equine behavior and postulates, “Experienced horse people may come into contact with the horse with expectations and, in the horse’s experience, are likely to issue demands whereas a more nervous person with no experience would act differently and induce less stress.”

Merkies looks forward to future research studying how the personality of horses and humans mesh, particularly involving the



Photo by: Dr. Katrina Merkies

Marnie McKechnie, research assistant with Sunrise horse Luke

role of attachment theory in horse-human relationships. The question arises: Is there a certain personality horse that is better suited for a role in therapy programs?

Funding for this research has been provided by the Horses and Humans Research Foundation.

By: Jackie Bellamy-Zions

Sponsored by Merck Animal Health

Equipment and Expertise at OVC Make Strides in Diagnosing Equine Leukemia

Equine leukemia is a rare and terrible disease which is challenging to diagnose,” says Dorothee Bienzle, Ontario Veterinary College researcher. In a recent three-month study, Bienzle with the help of graduate veterinarian Carina Cooper, compiled information from the last 16 years of cases of equine leukemia that came through the OVC. Over half of the 16 diagnoses have occurred in the last two years due to recent advances in detection.

When asked if cases were on the rise, Bienzle explained equine leukemia is still rare but difficulties in making a diagnosis can result in animals that die without a diagnosis. The criteria in testing horses is not as clear cut as it is for dogs and cats. The two main types of leukemia found (myeloid and lymphoid) are fairly straightforward to differentiate in dogs and cats but not so in horses.

“New technologies such as flow cytometry and immunohistochemistry, pioneered at OVC, have been fundamental to the increase in definitive diagnoses of equine leukemia in the past two years,” says Bienzle.

Acute Myeloid Leukemia (AML) and Acute Lymphoid Equine Leukemia (ALL) tend to have a grave prognosis with survival of days or weeks. There is a third type of leukemia, called Myelodysplastic Syndrome (MDS), which dogs, cats, humans and horses can have. This is also a cancer of bone marrow seen in the

more elderly. MDS typically progresses at a slower rate. The current treatment for MDS in equines is corticosteroids and the survival rate can be months to years allowing life as a companion animal during that time.

Hematology results of the study showed all cases as having atypical white blood cells in circulation, and in most cases there was high Serum Amyloid A (SAA), which is a protein produced in the liver that will rise in response to inflammation. Anemia, low neutrophil and low platelet counts are reasons to test further for equine leukemia.

For more information on Flow Cytometry at the Ontario

Veterinary College: [/www.ovc.uoguelph.ca/research/en/research/resources/flowcytometry.asp](http://www.ovc.uoguelph.ca/research/en/research/resources/flowcytometry.asp)

By: Jackie Bellamy-Zions



Photo by: Jackie Bellamy-Zions

New technologies such as Flow Cytometry, pioneered at OVC, are fundamental to the increase in definitive diagnosis of Equine Leukemia in the past two years

Always Something New at EquiMania!

Like branches of a tree, EquiMania! reaches out and captivates kids and adults into the wonderful world of horses. The impressive, new ‘tree of life’ display, showcasing the stages of foal development, complete with a video featuring the birth of a foal, was a big hit at the 10th anniversary of EquiMania! at the Royal Agricultural Winter Fair, last November in Toronto.

“Thanks to our loyal sponsors, EquiMania! will bring its fun, interactive youth exhibit promoting horse health and safety to audiences as far reaching as Omaha in 2017!” says Gayle Ecker, director of Equine Guelph. Equine Guelph thanks all our sponsors for their continuing support of the award-winning attraction: Greenhawk, Kubota Canada, Ontario Equestrian Federation, Shur-Gain, Standardbred Canada, SSG Gloves, System Fencing, Workplace Safety and Prevention Services and Zoetis.

To book EquiMania! for your event in 2017, contact eq4kids@uoguelph.ca



Photo by: Jackie Bellamy-Zions

We Have You Covered

In 10 - 15 minutes you can gain feedback tailored to your horse health care needs.

From the new ThermoRegulator to the Vaccination Equi-Planner, there are interactive questionnaires, checklists and personalized print outs, all designed to provide practical recommendations to optimize horse health.

Free videos, info-graphics, and interactive graphic activities provide engaging and easy to understand health tips that you can use today.

Visit all the Interactive HEALTHCARE TOOLS at EquineGuelph.ca

Equine Guelph thanks the following animal health companies for their sponsorship:

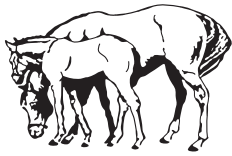

EQUINE GUELPH
helping horses for life



Boehringer
Ingelheim

SENIOR HORSE CHALLENGE



THERMOREGULATOR



HEARTLAND
FARM MUTUAL

BARN FIRE PREVENTION



INTERCITY[®]
INSURANCE
SERVICES

COLIC RISK RATER



BIOSECURITY RISK CALCULATOR

Be Empowered

HORSE HEALTH TRACKER
from EQUINE GUELPH

- install
- review
- share

Download on the App Store | **Get the App** | GET IT ON Google play

EVENTS

Mark your calendar!

Can Am All Breed Equine Expo (Markham) – EquiMania!
March 31 – April 2

Equine Welfare – Canada’s Code – Online training
March 6 - 24

Equine Biosecurity – Canada’s standard – Online training
April 10 - 28

Equine Guelph’s 12 week Online Courses
(Next offering May 2017)

Visit EquineGuelph.ca and TheHorsePortal.ca for more course information.

Anyone wishing to excerpt Equine Guelph should contact: Jackie Bellamy-Zions ext 54756 jbellamy@uoguelph.ca

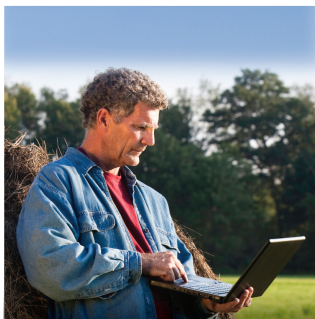

educating
horsepeople



funding industry
research



promoting health
& performance

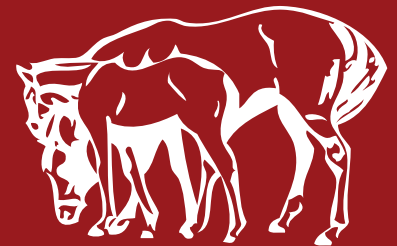

EQUINE GUELPH
helping horses for life™